

Instruction Manual

Olymberyl® HF217-SE Baby Gabriel

Defra Smoke Exempted Free-standing

Non-Boiler Wood Burner

Baby
Gabriel®

Published November 2013

Please note This appliance has been independently tested and approved by Defra as an 'exempted appliance' to allow the burning of wood in designated UK Smoke Control Areas (see page 13). It must, at all times, be operated in accordance with the instructions to minimise the amount of smoke produced.

You will need to refer to the serial number of your stove shown above should you ever need to make a claim under the Hi-Flame Warranty. You will also find the serial number, beginning with HF, on the CE plate at the rear of the stove as well as on the lid of the outer packaging.



This appliance has been approved by Hetas

This appliance has been approved by Hetas Limited specifically as an intermittent operating appliance for burning wood only. Please note that *Hetas Limited Appliance Approval* only covers the use of wood fuels in this appliance. *Hetas Limited Approval* does not cover the use of other fuels, either alone or mixed with wood, nor does it cover instructions for the use of other fuels.



CONTENTS

	Page
Introduction	4
Packing List	4
Installer Safety First	5
Standard Features	6
General Dimensions	7
Technical Data / CPR	8
Important Safety Advice	9
Assembling the Stove	10
Flue Options	11
Installation Regulations	12
Smoke Control Areas	13
Recommended Fuels	14
Prohibited Fuels	15
Important: First Fires	16
Burning Wood Logs	16
Lighting a Wood Fire	17
Some Simple Tips	21
Removing Ash	22
Installation Check-list	23
Installation General Guidelines	25
Commissioning	28
Trouble-shooting	29
Standing Down	34
Routine Maintenance	34
Hi-Flame Warranty	38
Annual Service	40
Service Record	41
Spares Service	Back Cover

USER WARNING NOTE

Properly installed, operated and maintained this stove will not emit fumes into the dwelling.

Occasional fumes from removing ash and refuelling may occur. However, persistent fume emission is potentially dangerous and must not be tolerated.

If fume emission does persist, then the following immediate action should be taken:

- Open doors and windows to ventilate the room and then leave the premises
- Let the fire go out
- Check for flue or chimney blockage and clean if required
- Do not attempt to relight the fire until the cause of the fume emission has been identified and corrected. If necessary seek expert advice

The most common cause of fume emission is flueway or chimney blockage. For your own safety these must be kept clean at all times see page 34.

If the CO alarm (which should be fitted at the time of installation) sounds, please follow the advice above.



Please note: From 1 September 2014 a CO alarm will now be a mandatory requirement for all stove installations in the Republic of Ireland.

INTRODUCTION

Thank-you for purchasing the Baby Gabriel stove. We are confident that it will warm your home even on the coldest winter days and provide you with many years of pleasurable heat.

Before you install or operate your stove however, please read this booklet which contains important safety advice as well as instructions which will help you to make the most of your new stove.

All users of this stove should be aware of the contents of this handbook. If other people are going to operate the stove then please keep this booklet handy so that it can always be quickly referred to.

Never let anyone use the stove who may be unfamiliar with its correct operation.

If installed in a UK Smoke Control Area this stove must be operated in accordance with the instructions to minimise the amount of smoke produced.

PLEASE NOTE *This instruction manual is also used for a number of other free-standing stove models in the Hi-Flame product range and therefore some of the stove photographs and diagrams used, which are used for guidance purposes only, may differ slightly from your new Baby Gabriel stove. However, the principles illustrated here remain the same.*

Hi-Flame Fireplace (UK) Limited

PACKING LIST

As soon as you receive your new stove please check that you have a full set of components as set out in the list below. In the unlikely event of a shortage, please report this immediately to the dealer you bought the stove from. Never attempt to operate the stove with missing or damaged components.

Product Information

- 1 Instruction Booklet
- 1 Warranty Card

Stove Components

- 4 Legs
- 6 30mm Leg Fixing Bolts (2 spare)
- 6 Leg Fixing Bolt Washers (2 spare)
- 4 Leg Height Adjustment Bolts
- 1 Handle Cover
- 1 Handle Cover Securing Bolt
- 3 Log Retaining Bars

Equipment

- 1 Ashpan
- 1 Operating Tool

Tool Bag

- 1 Safety Mitten
- 2 Spare Glass Retaining Clips
- 2 Spare Glass Retaining Clip Screws
- 1 Spare Rope Seal (for door)
- 1 Allen key (for door hinges)



INSTALLER SAFETY FIRST

BS 8303 Code of Practice

Please refer to the current issue of British Standard BS 8303, Code of Practice for installation of domestic heating appliances burning solid mineral fuel. Make reference to Building Regulations, Local Authority Byelaws and other specifications / regulations as they affect the installation of this appliance. See page 12.

Health and Safety

During the installation of this stove and any related building works you must comply with any current Health & Safety at Work regulations. When the stove is fired up always wear protective gloves and use the tool supplied when adjusting the stove's air controls.

Asbestos

This stove does not contain Asbestos. However, check that there is no possibility of disturbing any asbestos based materials during its installation. You may intend removing an older appliance prior to installing your new stove, and you should be aware that the old appliance or installation could incorporate heat protective asbestos sheet. Use appropriate protective equipment and seek specialist guidance at www.hse.gov.uk/asbestos – do not underestimate the potential dangers of Asbestos.

Fire Cement

Some types of fire cement are caustic and should not be allowed to come into contact with the skin. Protective gloves and glasses should be worn when applying fire cement. In case of contact wash immediately with plenty of water. Always read and follow the fire cement manufacturer's instructions.

Care should also be taken to avoid unnecessary contact between the stove's surfaces and the fire cement as this could damage the paintwork. Any excess fire cement should be quickly removed before it hardens.

Handling

The Baby Gabriel stove is extremely heavy (83kg / 13st 10lb) and therefore adequate facilities must be available for its safe loading, unloading and site handling.

Metal Parts

When installing or servicing this stove care should be taken to avoid the possibility of personal injury from the stove's metal parts. Particular care should be taken to avoid sharp edges when handling or attaching the flue liner.

STANDARD FEATURES

1 Primary Air Control

Adjusts the air which enters under the fire grate to boost the combustion process during the initial lighting phase when burning wood – not normally used after this stage.

2 Secondary Air Control

Adjusts the air supply which enters at the top of the fire chamber to ensure cleaner more efficient wood burning. Part of the airwash system

3 Airwash System

Part of the secondary air control system which diverts pre-heated air down along the front of the glass to burn off unwanted dry sooty particulates and help keep it clean

4 External Control for Riddling Grate

Allows fuel to be riddled without opening the fire chamber door

5 Top or Rear Flue Option

Simple to switch depending on the type of installation

IMPORTANT

In the interests of safety please read these instructions carefully before installing or operating your new stove. Even if you have installed or operated stoves before, manufacturer's requirements can vary and can also change with updates to building regulations. If installed in a UK Smoke Control Area this stove must be operated in accordance with the instructions to minimise the amount of smoke produced.



GENERAL DIMENSIONS

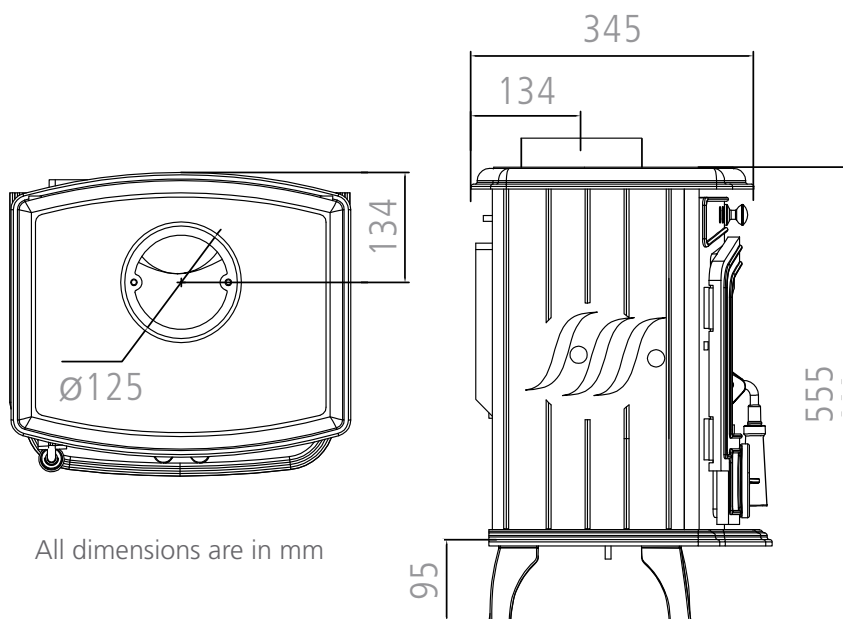
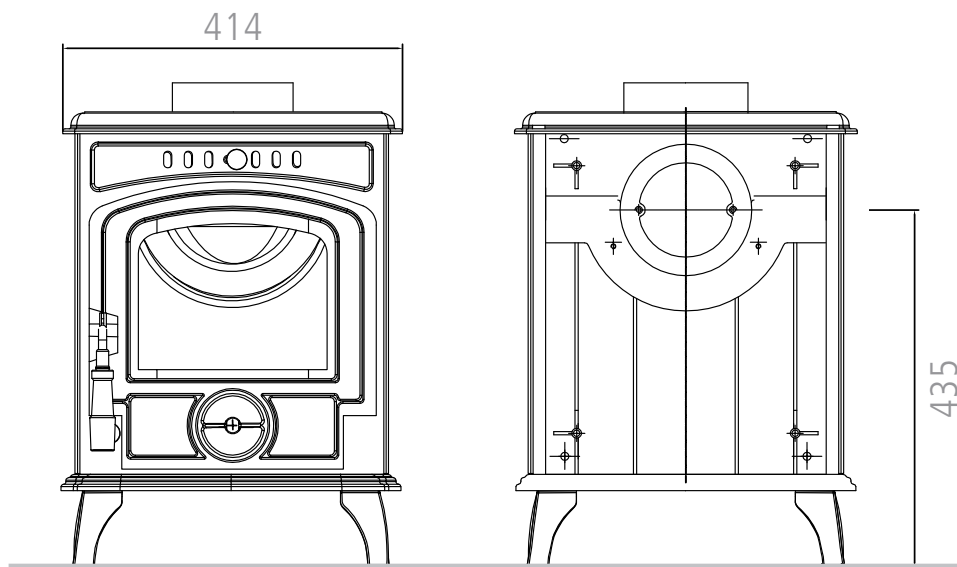

All dimensions are in mm

TECHNICAL DATA / CPR DECLARATION OF PERFORMANCE

Construction Products Regulation Declaration of Performance (DoP)

Hi-Flame Fireplace (UK) Limited declare that the test stove submitted for type testing of the HF217-SE model represented the full production model specifications in all critical technical parameters needed to fulfil the requirements of the testing standard BS EN 13240:2001 + Amd 2:2004.

No modifications were required to the items tested in order to meet the requirements of the standard.

All applicable criteria on the type test have been passed in respect of the materials, design and construction as well as the instructions and marking. Data derived from Kiwa GasTec BS EN 13240:2001 tests during September 2012 (report number 6621).

General Specification

Model Name	Olymberyl Baby Gabriel
Model Number	HF217-SE
Overall Height	555 mm
Overall Width	414 mm
Overall Depth	345 mm
Net Weight	83 kg
Gross Weight (packed)	91 kg

Data from CE Test EN13240

Burning Wood Logs:

Nominal Heat Output	4.6 kW
Refuelling Interval	45 minutes
Efficiency (net)	75.0%
Mean CO Emission (at 13%)	0.25
Mean Flue Gas Temperature	296°C
Flue Gas Mass Flow	4.5 g/s

Minimum Distance to Combustibles

Rear	450 mm
Sides	350 mm

NB *We do not recommend the use of mantels made from combustible materials such as wood*

Non-combustible Hearths

At a nominal output of 4.6kW and when operated in accordance with these instructions this stove is suitable for use with a 12mm non-combustible hearth – subject to current Building Regulations.

Tested hearth temp (Wood)	30.4°C
---------------------------	---------------

Fuel Requirements

Hardwood Logs:

Moisture content	<20%
Maximum Log Length	250 mm
Maximum Fuel Load	1.5 kg

Flue Requirements

Flue configuration	top or rear
Flue pipe diameter	125 mm
Height to centre of rear flue	435 mm
From centre of top flue to back	134 mm
Minimum flue height from base of stove	4500 mm
Minimum flue pressure	12Pa

Air Supply

A permanent means of ventilation may be required for this stove in accordance with the guidelines given in current Building Regulations – please also see page 24.

IMPORTANT SAFETY ADVICE

- Ensure that an approved carbon monoxide detector (BS EN50291:2001) is fitted in the same room as the stove. It should be powered by a battery designed for the working life of the alarm. *Please note* that since October 2010 this is now a requirement under UK Building Regulations.
- External surfaces including the fire-chamber door and operating handles, windows, flue pipes and stove bodywork will become extremely hot. Always use the tool provided and avoid touching these parts of the stove without proper protection, such as heat resistant gloves or other protective aids.
- Potentially combustible material or objects such as soft furnishings should never be left on or near any of the stove's hot surfaces. Ensure that wood supplies and log baskets are kept at a safe distance from the stove.
- Never leave children unattended in the room where your stove is being operated. Ensure that children are aware of the potential danger and make sure that they keep clear of the stove when it is in operation. Where children, the elderly or the infirm are present, to prevent accidental contact with the stove, always use a safety fireguard manufactured in accordance with *BS8423:2002, Fireguards for use with solid fuel appliances*.
- This stove should *not* be fitted in a room with an extractor fan (eg kitchen) as this will adversely effect the air quality in the room and could be dangerous for the room's occupants. It will also starve the stove of combustion air and reduce the stove's efficiency.
- To ensure your safety make sure that your stove's installation complies with all local building regulations' ventilation requirements. Low energy houses have their own particular requirements and should be strictly adhered to.
- Do not use flammable liquids to ignite the fire. In the confined space of the firechamber there is a real potential to cause a life-threatening flash flame or explosion.
- Never over-fire the stove. If any external parts of your stove glow red during operation then immediate action should be taken to reduce the supply of air to the firechamber through the Primary and Secondary air controls which should quickly limit the intensity of the fire.
- This stove is CE approved and tested to EU EN13240 standards in the UK by Kiwa GasTec. Alterations to its construction could be potentially dangerous and will render your product warranty void.
- Do not use aerosol products in the vicinity of the stove when it is in use.
- Check and clean the stove's flueway and the top of baffle plate regularly to help avoid potential blockages (see page 34).
- Clean your chimney regularly (see page 35).

ASSEMBLING THE STOVE

Your new cast iron stove is extremely heavy. Always handle it with care and make sure that you have additional strong help when you move it.

The ash lip on the Baby Gabriel® is factory fitted and, along with the door and door handle, should not be used to grip the stove as they could be damaged from supporting the stove's weight. Items, such as fuel retaining bars, can be removed to help reduce the weight. Under no circumstances should the door be removed as this will invalidate your Hi-Flame Warranty.

- **Unpack** Remove your new stove from its recyclable packaging. Retain this until the stove is installed and is fully operational. Unfasten retaining wires and remove any components, including those inside the ash pan, from inside the stove

- **Inspect** Please inspect the stove to check that it has not been damaged in transit – never attempt to install a stove which has been damaged. If damage is suspected then report this immediately to your stove dealer

- **Check List** Study the component packing list on page 4 and make sure that you have all of the components listed before proceeding. Some components are contained within the ash pan

- **Legs** Gently lay the stove on its back to access the base. Use old carpet or cushions to prevent damage to the back of the stove. Remove the four bolts at each corner of the base of the stove.

These are to protect the leg bolt hole threads during the production process. Use machine oil to lubricate the leg bolts before fitting each of the legs. The washer is fitted between the bolt head and leg flange. Do not over-tighten these bolts as this will damage the cast iron.

Return the stove to the upright position being careful to help ease the weight and pressure on the rear legs. Do not drag the stove once the legs have been fitted. Always lift the stove to finally position it. Alternatively it may be possible to place the stove on heavy duty plastic sheeting or thick floor covering to slide the stove into position, being careful not to damage any finished floor surfaces with trapped grit or building debris

- **Baffle Plate** Check the position of the baffle plate (sometimes known as the throat plate) inside the 'roof' of the stove to ensure that it has not moved during transit. This is a heavy metal plate which directs flames and helps retain heat inside the stove. The base of this plate should sit securely on a small ledge at the back of the firechamber, towards the top. The rest of the plate is supported by two additional retaining lugs at the top middle of the side firebricks to maintain it at the correct angle and in line with the top of these side firebricks. It is best to fully familiarise yourself with the baffle plate's correct location by practising removing it and re-fitting it prior to the stove's installation as you will need to regularly check the top of this plate and the access to the flueway to avoid

potential soot build up and blockages. Once you know how to do this it is a very easy operation. See page 34

- **Handle Assembly** Thread the split washer along the handle bolt. Feed the bolt and washer through the handle grip. Use a Phillips crosshead screwdriver to attach the assembled grip to the door handle clamp mechanism on the door, being careful not to over-tighten.

Your stove is now ready for installation.

- **Moving** Do not drag the stove. Always lift the stove to finally position it. Alternatively it may be possible to place the stove on heavy duty plastic sheeting or thick floor covering to slide the stove into position, being careful not to damage any finished floor surfaces with trapped grit or building debris.

- **Flue Options** The HF217-SE stove is delivered already configured for a rear fitted 125mm (5") flue pipe but can easily be switched to the top fitting flue option. To do this see right.

FLUE OPTIONS

The HF217-SE stove can be configured for a 125mm (5") top or rear flue outlet. Under no circumstances should the flue pipe diameter be reduced from 125mm (5") as this could be extremely dangerous.

Remember, a top flue outlet will always be the most efficient choice if it can be undertaken safely.

The HF217-SE stove is delivered already configured for a rear fitted 125mm (5") flue pipe but can easily be switched to the top fitting flue option. To do this remove the 'hob' from the lid of the stove by unscrewing the two bolts. Always use the correct sized Phillips crosshead screwdriver and be careful not to damage the bolt heads as these will be re-used. This cover and sealing gasket can now be re-used as a blanking plate to seal the rear flue aperture once the flue collar has also been removed.

Ensure that the rope gasket is positioned correctly to make a good all-round seal between the collar and plate. Lubricate the new bolt holes with machine oil to avoid damaging the cast iron threads. Heat-resistant cement may also be required to ensure an adequate seal between the stove and components. Avoid getting fire cement on the paintwork by masking the immediate working area. Any excess fire cement should be removed immediately.

INSTALLATION REGULATIONS

You must ensure that your stove is installed by a recognised competent person who is appropriately qualified in the installation of stoves and that the installation complies with all local, national and European building regulations.

In the UK we strongly recommend using a Hetas registered installer (www.hetas.co.uk) and in Ireland a registered installer from INFO – the Irish Nationwide Fireplace Organisation (www.fireplace.ie). Your authorised Hi-Flame dealer will also be able to help and advise you.

For further information on local Building Regulations please consult:

England & Wales

Building Regulations Document J (revised October 2010) – Combustion Appliances and Fuel Storage Systems
www.planningportal.gov.uk

Scotland

Building Standards (2001) Domestic
www.sbsa.gov.uk

Northern Ireland

The Building Regulations (Northern Ireland) 2000 / Amendment 2006 / Amendment No 2 2006
www.buildingcontrol-ni.com

Isle of Man

Building Regulations (2007) – Isle of Man
www.gov.im

Republic of Ireland

Approved Document J – Heat Producing Appliances (Revised September 2014)
www.environ.ie

Other Information Points

For additional useful information and links to the government websites above, including informative downloads, visit The Solid Fuel Technology Institute website www.soliftec.com.

The Solid Fuel Association website is also a very good source of practical information and downloads
www.solidfuel.co.uk.

The British Flue and Chimney Manufacturers Association website, www.bfcma.co.uk produces an authoritative and informative download guide to solid fuel flues and chimneys.

Buildings Insurance

It is a requirement by some building insurance companies to inform them of the installation of a new fixed heating appliance and a relevant certificate of compliance produced.

Health & Safety

During the installation of this stove and any related building works you must comply with any current Health & Safety at Work regulations.

YOUR LEGAL OBLIGATIONS IF YOU LIVE IN A UK SMOKE CONTROL AREA

The Clean Air Act 1993 and Smoke Control Areas

Under the Clean Air Act local authorities may declare the whole or part of the district of the authority to be a Smoke Control Area.

It is an offence to emit smoke from a chimney of a building, from a furnace or from any fixed boiler if located in a designated Smoke Control Area. It is also an offence to acquire an 'unauthorised fuel' for use within a Smoke Control Area unless it is used in an 'exempt' appliance ('exempted' from the controls which generally apply in the Smoke Control Area).

The Secretary of State for Environment, Food and Rural Affairs has powers under the Act to authorise exempt appliances for use in Smoke Control Areas in England. In Scotland and Wales this power rests with Ministers in the devolved administrations for those countries. Separate legislation, the Clean Air (Northern Ireland) Order 1981, applies in Northern Ireland. Therefore it is a requirement that fuels burnt or obtained for use in smoke control areas have been 'authorised' in Regulations and that appliances used to burn solid fuel in those areas (other than 'authorised' fuels) have been exempted by an Order made and signed by the Secretary of State or Minister in the devolved administrations.

Further information on the requirements of the Clean Air Act can be found at the following website: www.smokecontrol.defra.gov.uk.

Your local authority is responsible for implementing the Clean Air Act 1993 including designation and supervision of Smoke Control Areas and you can contact them for details of Clean Air Act requirements.

The Baby Gabriel HF217-SE has a factory-fitted modified control damper to prevent closure of the main air control beyond the 50% open position and has been recommended as suitable for use in Smoke Control Areas when burning wood logs.

RECOMMENDED FUELS

• **Hetas Approval** *Please note that Hetas Limited Appliance Approval only covers the use of wood fuel in this appliance. Hetas Limited Approval does not cover the use of other fuels, either alone or mixed with wood, nor does it cover instructions for the use of other fuels.*

• **Defra Smoke Exemption** The Baby Gabriel HF217-SE stove is approved by Defra as an 'exempted appliance' to allow the burning of wood in designated UK Smoke Control Areas. It must, at all times, be operated in accordance with the instructions to minimise the amount of smoke produced.

The following fuels are approved by Hi-Flame for use in the HF217-SE:

• **Wood Logs** *Only ever use dried, fully seasoned chopped wood logs with a moisture content of less than 20%.*

Wood which is well seasoned makes a distinctive 'clack' rather than a dull 'thud' when knocked together. It will also feel much lighter than an unseasoned log. Other indicators include bark peeling away and cracking and splitting around the outside.

Ideally wood should be seasoned outdoors for between 18 to 24 months – the harder the wood then the longer the seasoning. It should be stacked off the ground with plenty of space between the logs to allow air movement and with the top covered to keep rain and snow out. Seasoned wood will give you approximately 50% more heat output than the equivalent unseasoned log.

Most types of hardwood, for instance Ash (generally regarded as the best), Birch, Beech, Oak and Elm can be used. However, avoid woods with a high resin content. As a rule of thumb, the heavier the wood, then the greater the heat output and the longer burn time – the time between refills. All of this is providing it is fully seasoned wood.

Never use wet or unseasoned (green) wood as this will cause nuisance smoke and a very disappointing fire.

It could quickly result in the build up of soot and creosote which, because of the higher temperatures of stove flue gases, could easily cause a flue or chimney fire. In addition, burning wet wood creates other environmental problems, a less efficient fuel economy and can eventually clog your flue system and cowl. It will also reduce the effectiveness of the stove's Airwash system thus causing staining and blackening of the glass.

Wet or unseasoned wood produces the following poor performance:

- Hard to light fires
- Fires that are difficult to keep going or to keep burning well
- Smoky fires with fewer flames which are also of a dull orange colour
- Increased dense grey / blue smoke from the chimney
- Shorter burn times
- Low heat output
- Dirty glass and firebricks
- Excessive and rapid creosote build-up in the flue system and chimney
- Unpleasant smoky smells both inside and sometimes outside the house

Manufactured or finished wood products, such as plywood and chipboard, must also be strictly avoided because of the high chemical adhesive content used in their production which will also leave harmful residue inside the stove and flue system.

For more information about wood fuel visit the Defra funded National Energy Foundation website *Logpile* at www.nef.org.uk/logpile.

PROHIBITED FUELS

Never use your stove like an incinerator

Burning prohibited 'fuels' is an offence in a Smoke Control Area and could create nuisance smoke which may also be an offence in non-Smoke Control Areas.

Hi-Flame do not recommend burning the following fuels:

- **Smokeless Mineral Fuels** The Defra Smoke Exempt configured version of this stove (SE) has not been CE tested for burning mineral fuels and therefore Hi-Flame do not recommend their use in this stove.

- **Petroleum Coke** Never burn petroleum coke as this burns at a very high temperature and its continued use will almost certainly cause irreparable damage to components such as the grate, baffle plate and fire bars.

- **Bituminous House Coal** is not recommended because it produces excessive soot deposits, which is not good for the environment, and also considerably increases the need for cleaning the stove and flue system.

- **Peat or Turf** Not suitable for burning in this stove.

- **Household Rubbish** Printed matter (excluding very small amounts of newspaper for starting the fire if necessary), plastic, rubber, lacquered or impregnated wood, plywood, chipboard and household rubbish, such as milk cartons, should also be avoided. During combustion some of these materials may develop substances which could be hazardous to your health and be harmful to the environment.

- **Flammable Liquids** Never use methylated spirits, petrol or other highly inflammable liquids for lighting the fire as these could cause an explosion in the confined spaces of the firechamber.

- **Wood products** Never burn any kind of tanned timber (pre-2006 products could contain dangerous arsenic pentoxide) or old painted or varnished timber or boards, which may contain harmful formaldehyde resins (this includes most plywoods, chipboard and MDF).

IMPORTANT: FIRST FIRES

Use smaller and shorter 'gentle' fires the first five or six times that you fire up the stove, making these progressively bigger, as this will avoid any potential thermal shock and allow the cast iron components to 'acclimatise' with each other. Allow the stove to fully cool down between these fires.

When first using the stove it is normal to experience paint fumes or see light smoke rising from some of the stove's painted surfaces. During this stage ensure that the room has additional ventilation by opening doors and windows to minimise any adverse effects.

The hotter you burn the stove the more intense these fumes will be, which is one of the reasons that we advise that you use smaller fires to start with. Every time the stove reaches a new higher temperature it may still be possible to smell these fumes or see some gentle smoke until the paint work is fully cured.

If smoke and fumes persist do not use the stove and immediately consult your installer, as this may indicate that there could be a possible problem with the installation.

BURNING WOOD LOGS

Your new stove can burn very well, or very poorly, depending on how you light the fire, how you refuel the fire, and, of course, the type and quality of the fuel that you are burning. A flue temperature gauge and log moisture meter are both cost-effective investments and are highly recommended if you want to maximise the efficiency of your stove and fuel.

Wear protective gloves when loading a burning stove and place logs precisely where you want them by using heat-resistant tongs if necessary.

Always open the stove door gently to avoid unnecessary air turbulence due to the differences in air pressure between the stove and the room which could cause ash or small lighted embers to be drawn from the fire chamber and beyond the protective hearth. Never operate the stove without the fire fence (or log guard) in position.

The stove is not designed to be operated with the door open.

The Wood Fire

Wood takes its combustion air from the top of the fire chamber so understanding how and you use the Secondary air control (which also controls the airwash) at the top of the stove is important.

Wood will always burn best on a bed of its own embers which also forms a barrier that helps reflect the heat and protects the fire grate from being damaged. Therefore you should leave a bed of ash in place to create a layer of approximately 25mm (1"), only

occasionally ridding or removing the surplus ash.

The end grain of the wood produces more of the remaining moisture and gases so whenever possible point the log ends away from the glass to help keep the glass clean.

The Fuel Load

Ideally the logs should be approximately 225 – 250mm (9" – 10") long and a typical fuel load should weigh 1.0 – 1.5kg (2.2lb – 3.3lb).

To get the best out of your stove, you will need three different thicknesses of wood log as you build the fire through each lighting phase:

A Kindling This is generally finely chopped wood, approximately 5 to 10mm thick (1/4" to 1/2") from your supply of logs. Alternatively use dried twigs or small branches which have also been fully seasoned

B Lighting Logs These are slightly bigger diameter logs, approximately 25 to 50mm (1" to 2")

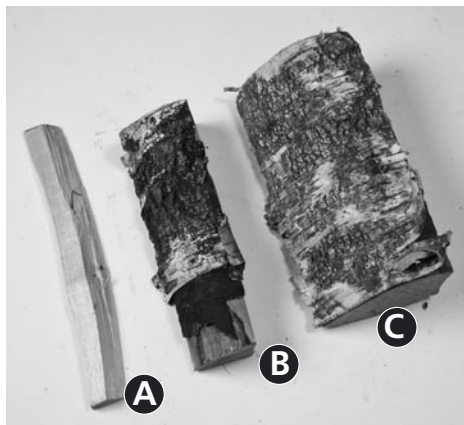

C Refuelling Logs These should be approximately 75 to 100mm thick (3" to 4"). Bigger logs should be split down to this size

Lighting a wood fire

The main difference between smoke and flame is temperature, so when lighting a fire you need to get the temperature in the firechamber as high as possible as quickly as possible. This is also critical in creating a good 'draw' within the flue system, especially when it is particularly cold outside.



The recommended maximum fuel load: Photo shows a typical loosely stacked fuel load of approximately 1.5kg of fully seasoned wood logs approx 250mm (9") long by 75 – 100mm thick

When flue gas temperatures are below 120°C, creosote tars form within the gases and the fire will be smoky and burn with a dull orange flame. Burning the stove like this for a sustained period will create unnecessary smoke and not be good for the chimney or flue system.



Use the tool provided to adjust the Secondary air / Airwash control at the top of the stove



The Primary air the base of the stove door is opened, using the tool, by turning anti-clockwise

1 The Lighting Phase

For best results:

Primary Air – fully open

Secondary Air – fully open

Door – slightly ajar (optional)

Avoid trying to light the fire with excessive amounts of paper as this has a very high ash content which can 'smother' the ash bed. If you have good dry kindling or sticks then paper should not be needed at all.

The size of the logs used at each stage is also important. If the kindling wood is too large this will not light well and will be slow to get started. Two handfuls of smaller pieces of kindling (equivalent to the weight of typical log) layered in a criss-cross or 'wig-wam' and a small firelighter will get the fire well established and up to operating temperature quickly.

If you feel you have a weak chimney draught, then keeping the stove door slightly ajar for the first 10 – 15

minutes will assist, after which it should be closed. This will also help prevent the build-up of condensation on the door glass until the glass warms up, especially if you have not used the stove for a few days.

During the lighting phase the Primary and Secondary air settings on the stove should be fully open.

2 The First Refuel Phase

For best results:

After 10 minutes

Primary Air – close completely

Secondary Air – fully open

Door – closed

Once the embers are starting to glow and the flames start to calm down the first refuelling can take place. For this stage use slightly larger pieces of wood than the lighting wood – but smaller than the main refuelling wood in the next phase. The reason for this is that the embers from the kindling wood are small and will not hold a high

temperature for too long.

If unnecessarily large pieces of wood are placed on the embers at this stage and do not ignite well there is a risk that the firebox will cool down and the wood start to smoke. When the first refuelling wood is burning well (say, after about 10 minutes from the start) the Primary air can be completely shut off.

3 The Main Firing Phase

For best results:

After 17 or 18 minutes –

Secondary Air – adjust to suit

Primary Air – remains closed

Door – remains closed

Once the embers of the first refuel phase are glowing then these can be evenly spread with a poker or companion tool and the main refuelling wood can be quickly set.

Wood burns best if the flames have other wood to 'play off'. For example a

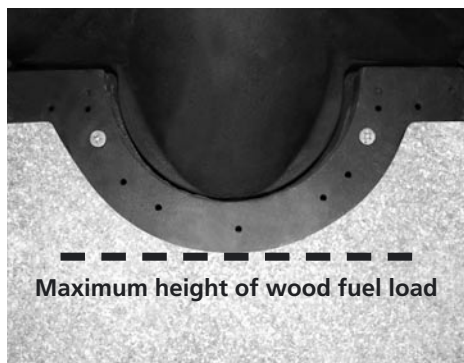

Maximum fuel load: This should never be higher than the lowest part of the semi circle cut-out shape in the rear firebrick as shown. Ensure that logs are secure behind the front fire fence so that there is no possibility of them rolling out

single dense piece of wood or log will not burn as well as 2 or 3 smaller logs of equivalent mass. The more contact the wood has with each other piece, the hotter the embers will be. 3 or 4 logs tightly packed to each other will burn longer but at a lower temperature than loosely criss-crossed logs.

Approximately 1.0 to 1.5kg of wood logs can be added at this stage. Be careful not to add too many logs as they may 'smother' the fire.

Try to avoid setting the ends of the logs pointing towards the glass as this can cause staining which the Airwash may find difficult to remove.

Only reduce the Secondary air control when the wood has 'carbonised' and the fire is burning at a high temperature. This is when the ash on the burning wood looks light grey and virtually covers all of the wood. A flue temperature gauge will be invaluable.

You will be able to tell when the stove is at this stage by studying the colour of the burning surfaces – the 'lighter' they are the better the wood is burning. If the log surface is predominately black and / or the flames are a dull orange then there is still some time to go before the fire is operating at full temperature.

Never leave the stove unattended after refuelling until the flames are well established on the new logs. Always load onto a bed of hot embers.

Once the fire is established the flame pattern can then be adjusted to your requirements with the Secondary air (Airwash) control.

Getting the balance right between a gently burning stove and one that is burning too slow, creating smoke and causing the Airwash to fail and consequently the glass to stain is very much a matter of trial and error. If you are burning well-seasoned wood then a quick 'blast' of the stove operating at 'full throttle', with Secondary and Primary air fully open, should quickly burn off any deposits left from any slower burning phase.

4 Refuelling

For best results: *Just before you refuel –*
Primary Air – fully open
Secondary Air – fully open

After loading and when new fuel is burning well –

Primary Air – close completely
Secondary Air – adjust to suit

Regular, smaller loads are better because they keep the firechamber at a higher temperature, without over-firing it. The higher operating temperature helps prevent nuisance smoke and sooty deposits.

Never overfill the firechamber and also avoid over-sized pieces of wood which will 'slow' the fire down at the start but then could lead to over-firing.

Before refuelling open the Primary and Secondary air supply so that there is a good strong fire so that the embers are glowing red which will help the new fuel to start burning quickly. This will also ensure that there is no build-up of harmful gas which could be released into the room when the firechamber door is opened.

Rake the embers and spread them out

to make an even bed. You may need to add some kindling to re-establish the fire. Add the new wood as before ensuring that the logs are not tightly packed.

Newly refuelled wood always requires some additional air so make sure the Secondary air is back in the fully open position after refuelling. Do not adjust the Secondary air until the fire is burning well and you can see bright yellow vigorous flames. Once the fire is established, usually after 5 minutes, close the Primary air and adjust the flame pattern again to your requirements with the Secondary air (Airwash) control.

Refuelling on to a low firebed

When refuelling you must ensure that there is a sufficient quantity of glowing embers and ash so that the new fuel charge will quickly ignite. Refuelling on an inadequate bed of embers will create excess smoke and will take much longer. It is very much easier and quicker to 'start' again by adding a suitable quantity of kindling to the remaining embers ensuring that there are sufficient brightly burning flames before medium sized logs are added.

IMPORTANT: Fuel overloading

The maximum amount of fuel specified in this manual (see page 8) should not be exceeded. Overloading can cause excess smoke and is also dangerous.

Operating with the door open

This stove is not designed to be operated with the door left open, except as directed in these instructions. This can cause excess smoke and can be

dangerous (see pages 16 – 21).

Operating with the air controls left open

Using this stove with the air controls left open can cause excess smoke. This stove must not be operated with air controls or door left open, except as directed in these instructions (see pages 16 – 21).



The recommended maximum fuel load: Photo shows a typical loosely stacked fuel load

SOME SIMPLE TIPS

- 1** When refuelling use small regular loads as this will produce a more efficient and cleaner burning performance.
- 2** If you have inadvertently let the fire burn down so that there are just a few burning embers then avoid reloading with large 'cold' logs as the fire will be very slow to re-establish itself, possibly even going out as the new load reduces the existing fire's access to a sufficient supply of combustion air.
- 3** Avoid burning large amounts of wood with the Secondary air supply turned down as this will reduce the effectiveness of the Airwash system producing dirty glass, as well as excessive smoke and a potential build-up of creosote tars.
- 4** Burn on a high output for approximately 30 minutes each day to 'burn off' any potential soot and creosote build-up – but be careful not to over-fire the stove. This is particularly important if you regularly burn low for long periods such as overnight burning.
- 5** Bright vibrant flames and a clean firechamber indicate that your stove is operating well. Lacklustre dirty orange flames indicates a poor performing stove which will produce excessive smoke and little heat – see the Troubleshooting section on page 29.
- 6** Never overload the stove – it will be smoky and inefficient as well as very slow to establish a good burn and could possibly eventually over-fire.

REMOVING ASH

Wood will produce a lot less ash than multi fuels and it would not be unrealistic to expect to empty the ash pan every two or three days, depending on the fuel loads and operating times. Remember, you do not need to riddle wood ash during firing, but possibly only at the start when some Primary air is needed to aid the initial combustion. Wood ash can be composted and recycled in the garden.

However, if you intend to burn multi fuels then you should expect to empty the ash pan at least once a day, again depending on the number of hours you burn the stove.

Using a poker, riddle any ash or embers to help clear the grate. Riddling allows the ash to fall into the collection pan below the fire bed. The ash pan should never be allowed to over-fill as this will limit the Primary air flow and cause



Use the forked end of the Baby Gabriel multi-purpose tool to move the external riddler backwards and forwards to clear ash from the shaker grate as shown



The forked end of the multi-purpose tool is inserted underneath the ash pan handle grip as shown above to create the ash pan handle. Always protect floor coverings from potential fly-ash

excessive heat build-up which could eventually warp or burn out the grate.

Locate the operating tool in the slot at the front of the ash pan to make a handle and lift the pan from the stove. For safety reasons ash should be removed when the stove is cold. If this is not always possible then extra care should be taken and decorative and combustible surfaces, such as laminate floors or carpets, should be protected against potential accidental spillage.

Remember, even if the stove appears to be cold the ash could still be hot with the possibility of hidden live embers. Protective gloves should always be worn and the refuse ash placed in a non-combustible container. As you remove the ash from your home ensure that it is covered to protect it from any draught or wind which could blow the ash out of your container. All of this becomes second nature once you have used your stove for a few days.

INSTALLATION CHECK-LIST

This information is intended to outline the general principles of installing your stove. However, as each installation will vary and must comply with local, national and European building regulations, which could be different from country to country, it is unfortunately not possible for these guidelines to be comprehensive.

- **Legal Requirements** Please note that, not only is it a legal requirement to ensure that your stove installation complies with all applicable building regulations, it is also a requirement of your Warranty that the stove is installed by a competent person such as a Hetas or INFO registered installer who will be fully aware of any building and safety regulations which apply to stove installations in your location.

Stove Location Check-list

- The existing constructional hearth (the main part of the hearth) is suitably constructed and is of a thickness that conforms to all applicable building regulations.
- The back hearth (the part of the hearth that the stove generally sits upon and which is usually within the fireplace recess or opening) is also suitably constructed and conforms to all applicable building regulations.
- The superimposed hearth (the thinner, usually decorative surface, which sits on the constructional part of the hearth) is suitably constructed and conforms to all applicable building regulations.

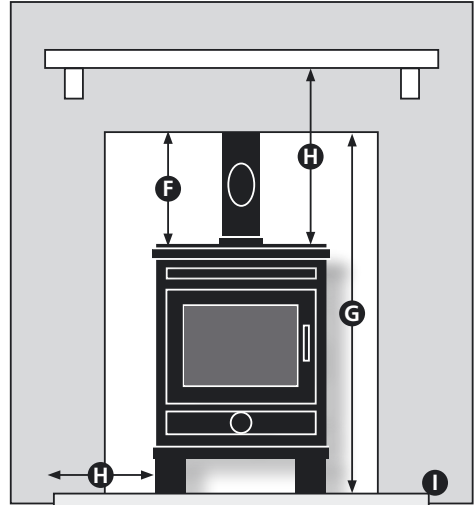
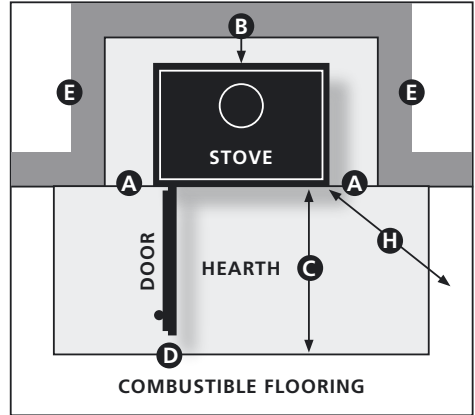

- **A** Minimum Air Space: Sides 150mm (6")
- **B** Minimum Air Space: Back 100mm (4")
- **C** Minimum hearth from stove front: 225mm (9")
- **D** or at least 50mm (2") beyond door swing
- **E** Fireplace walls minimum: 75 mm (3") thick
- **F** Minimum Height from lid to lintel: 300mm (12")
- **G** Ideal aperture height: 1200mm (48")
- **H** NB We do not recommend combustable mantels
- **I** Minimum hearth depth: 28mm (approx 1")

- The fireplace recess or opening is suitably constructed and conforms to all applicable building regulations and can accommodate the stove along with the safe minimum operating distances required – see page 25 opposite.

- Any adjacent walls, next to which a free-standing stove is installed, are of a suitable thickness and are of non-combustible material and conform to all applicable building regulations.

- Any extractor fan inside the room should be removed or permanently disabled.

The HF217-SE Baby Gabriel has been officially rated at a nominal output of 4.6kW. In homes built before 2008 stoves with an output below 5.0kW do not require a permanently open air supply within the room. For properties which have been built or modified so that their design air permeability is less than $5\text{m}^3/\text{h.m}^2$, (generally post 2008 homes) a permanent ventilator, which must conform to building regulations, for the full 4.6kW must be fitted. Building Regulations Approved Document J gives more detailed information.

- The chimney is of sufficient height, is suitably constructed and is in good condition and conforms to all applicable building regulations regarding stove installation. Please refer the to the current issues of British Standards *BS EN 15287-1:2007 Design, installation and commissioning of chimneys*.

The minimum flue height required for the Baby Gabriel is 4.5 metres (15') from the hearth to the top of the chimney terminal.

- The chimney has been swept and tested prior to installation.

- The proximity of all combustible materials to the intended stove installation conforms to the minimum requirements outlined within this handbook (page 8) as well as local, national and European building regulations, whichever is the greater. A combustible material is anything which can burn once it gets hot enough and includes skirting boards, wooden fire surrounds, wooden mantles, wallpaper, fabrics and floor coverings. Remember these materials could be concealed behind other materials which on the surface may appear to be non-combustible, for example, stud partitioned walls.

INSTALLATION – GENERAL GUIDELINES

Please refer specifically to current building regulations which apply to your country or region (see page 12). Adopt whichever provides the highest / safest margin.

The Hearth The hearth should be made of solid non-combustible material, set on a firm and level base and should be at least 125mm (5") thick. This can include the thickness of any non-combustible floor under the hearth or non-combustible decorative surface. It must be capable of supporting the weight of the stove (when loaded) along with any attached flue pipes which bear down on the stove. This hearth must conform to local building regulations which may vary from country to country.

In England and Wales there is a minimum requirement for the hearth to project 500mm (20") in front of any brick or stone recess and 150mm (6") at each side of the recess. For a free-standing stove the minimum hearth size should be 840mm by 840mm (2'10" by 2'10" approx) and should provide the minimum clearances for the stove which are outlined in this handbook. The hearth should extend by a minimum of 225mm (9") from the front of the stove (which includes the edge of the ash lip). As a general rule it is best to extend the hearth to at least 75mm (3") beyond the furthest out-swing of the stove door to avoid any potential live ash held on the door falling on to combustible flooring or

floor coverings. If the top of the hearth and any combustible floor coverings are level with each other then a retaining fender should be fitted to warn occupants of the hearth area.

Alternatively, a 28mm (1.1") change in level provided by a decorative non-combustible material such as stone, marble, granite, ceramic tiles etc could be used.

Please note that some materials, such as marble, may not be suitable when used as a single sheet and will need to be pieced together to allow for expansion from the heat of the stove. Your stove dealer or installer should be able to advise you about this.

The 'Fireplace' The stove can be sited within a brick or stone fireplace recess or used free-standing. The fireplace side and rear walls should be at least 75mm thick and made of non-combustible brick or stone. In a fireplace setting you should allow a minimum distance of 100mm (4") from the back of the stove and 150mm (6") at either side with at least 300mm (12") from the top of the stove. Ideally, the overall height of the fireplace aperture should be at least 1200mm (4') high.

Providing adequate air space around the stove will allow the stove to radiate heat and circulate warm air around the room. It will also prevent structural damage to the walls and potentially damaging over-heating of the stove. If it is not possible to maintain these spaces they could be reduced to 100mm (4") at the sides but only if this can be compensated with

twice the equivalent air space at the top of the stove and the non-combustible wall parts are at least 200mm (8") thick.

Walls adjacent to free-standing stoves should be made of non-combustible material and be a minimum of 200mm (8") thick.

Flue Draught This stove has been tested with a flue draught pressure of 12Pa. To ensure operation in line with the declared performance on page 8 the minimum flue draught requirement for the HF217-SE should therefore be a minimum of 12Pa.

The Chimney, Flue and Flexible Liners Other appliances should not share or be connected to the same flue system or chimney.

If you are using an existing chimney and it has been checked for condition and suitability (see below), in the interests of safety you must ensure that it is swept before the stove is installed, even if it has never been used or you intend to use a flexible liner.

To find a local registered sweep visit The National Association of Chimney Sweeps at www.chimneyworks.co.uk or the Guild of Master Chimney Sweeps at www.guildofmasterchimneysweeps.co.uk.

The recommended minimum height for the chimney / flue system from the top of the hearth base to the top of the chimney terminal is 4.5m (15'). If this is not possible then a 'spinner' type cowl, to compensate for the potential limited draught, should always be specified and

specialist advice sought on the correct type.

The Baby Gabriel features optional top or rear 125mm (5") diameter flue outlets and as a Defra Approved Smoke Exempt stove this *does not* require the installation specification to provide for an increasing adaptor to take the flue pipe and liner to 150mm (6") when burning wood.

Under no circumstances should the stove's 125mm diameter flue be reduced in any part of the flue system as this could cause a build-up of dangerous carbon monoxide gas.

A free-standing stove will generally require the flue to exit the room either through the ceiling, roof or wall. Therefore such installations require a specialist knowledge of building regulations and approved flue components which, unfortunately, is beyond the scope of these guidelines. In this instance always consult an approved installer who has experience of this type of installation.

When your new Hi-Flame stove is installed it should be possible to sweep the chimney through the stove by simply removing the baffle plate. However, the installer must also provide an alternative means, such as a soot door with adequate air-tight seal, in the chimney wall to be able to clean the whole of the chimney / flue system. In any event we would recommend that, where possible, the connecting flue pipe features at least one easily accessible inspection hatch near the top of the stove and that any bends which

have been used also have inspection hatches, irrespective of any other hatches in the system.

Flue gases from an efficient stove have temperatures which differ from those produced by an open fire or gas appliance so it does not necessarily follow that your chimney will function adequately (or safely) when your new stove is installed. Therefore the best way to ensure that you have a fully functioning flue system is to fit an approved flexible multi fuel flue liner.

Current Building Regulations in England and Wales do not yet automatically require an existing chimney to be lined when a new stove is fitted. However, Hi-Flame strongly recommend fitting a liner for the following reasons:

- A flue liner is a major 'quantifiable' component in a total and fully functioning flue system. As such it will provide a consistent flue draught from the stove through to the chimney terminal and when back-filled with vermiculite will deliver much needed insulation to keep flue gases as hot as possible which will help minimise the amount of smoke produced. It will also improve the stove's operation with greater control over the fuel burn rate and improved environmental and fuel efficiency.
- Your existing chimney could leak smoke, fumes and potentially dangerous 'invisible' carbon monoxide into other parts of the building.
- Condensation or creosote 'tar', often associated with burning wood, could eventually seep through the walls,

particularly if they are made of old or porous brick and / or are jointed with lime mortar, eventually causing unsightly stains on decorative coverings.

- Stoves work best with the correct draught. Pre-1965 chimneys which have been built for open fires have larger (and irregular shaped) voids than those best suited for a modern stove and this could reduce the effectiveness of the flue draught by making the flue too cold and difficult to warm. This is a particular problem if the chimney breast is on an outside wall and / or is subject to a strong prevailing wind.
- The interior surfaces of older flues could be eroded and also have rough surfaces which could cause resistance to the flow of gases and consequently result in poor up-draught.
- Unfortunately many houses built since 1965 with clay or concrete chimney liners suffer from these being poorly installed, either through being fitted the wrong way up or not receiving an appropriate application of mortar to make a complete seal on each joint. Even though not particularly old, this could still potentially cause leaking smoke and fumes or condensation stains

Your approved installer will be able to advise you on the suitability of your chimney after undertaking a thorough inspection and smoke test. Any solid fuel flexible liner which is specified should be double skinned stainless steel, either 904L or 316Ti grade and be CE marked and / or Hetas Approved.

The British Flue and Chimney

Manufacturers Association (BFCMA) produces an authoritative guide to chimneys and flues for wood burning and multi fuel stoves which can be downloaded from their website www.bfcma.co.uk.

Chimney Terminal The existing chimney pot or terminal must be suitable for stove installation and should not restrict the smoke and fumes from the stove. It must provide at least the same outlet area as the flue pipe. It may be that your existing chimney terminal has been replaced with a ventilating terminal if the fireplace has been closed off at some point and this will need replacing.

Your installer will be able to advise you on the correct specification of any new cowl or terminal. Cowls have the additional advantage of limiting rain entering the flue system which could cause the inside of the stove to rust when it is not being used, particularly during the long periods outside the heating season.

COMMISSIONING

- 1** Confirm that all internal parts of the stove are correctly fitted, including the baffle plate
- 2** Confirm that the door closes correctly and that the latch mechanism and door seals work to make an air-tight seal
- 3** Warm the chimney and carry out a final smoke draw test
- 4** Light the stove with a gentle fire, allowing the stove to increase to an operational temperature level and check that no combustion products are entering the room
- 5** Ensure that the Primary and Secondary air controls are fully operational
- 6** Explain the safe operation of the stove to the user and the importance of using the correct fuel types
- 7** Explain the requirements of using an approved fireguard whenever children, the elderly or the infirm are likely to be in the vicinity of the stove
- 8** Make sure that the customer receives this copy of the *Instruction Manual*
- 9** Complete the relevant parts of the *Hi-Flame Warranty Card* with your Hetas / INFO or competent persons registration number and contact details

TROUBLE-SHOOTING

CHIMNEY FIRE

If your stove has been installed correctly and you have also operated it correctly and regularly carried out the recommended routine checks on page 34 then it is unlikely that you will ever experience a chimney fire, which can be highly dangerous.

Chimney fires can be detected by an unusual roaring sound and / or unusual vibrations coming from the chimney breast, the stove itself or connecting flue pipe. The sound is not to be confused with the gentle 'rushing' sound you may normally hear when a stove has a well performing draught. You may also see sparks or flames exiting from the chimney terminal.

• **Prevention**

If you suspect a chimney fire then immediately close the Primary and Secondary air controls, evacuate the building and call the Fire Brigade. *Never* open the stove door as this will make the chimney fire worse by providing additional combustion air. Do not re-enter the building until you have been advised by the Fire Brigade that it is safe.

Do not re-light the stove until the flue system has been thoroughly inspected by an approved installer or chimney sweep and any necessary repairs have been carried out.

• **Causes: Inadequate cleaning**

Chimney fires occur when soot and creosote have built up to such a level that they ignite. It is important

therefore that your flue system, chimney closure (registration) plate and chimney has as many cleaning access points as practicable to enable comprehensive removal of soot, creosote and other debris from every point in the system. This will also minimise the amount of time it takes for a qualified sweep to clean the system making the system safer and its cleaning more cost-effective in the long run.

• **Causes: Continuous low burning**

To discourage the potential for such soot and creosote build-ups, long periods of consistent slow or overnight burning should be avoided or that these should at least be compensated for by regular burning on full output for short periods (eg 30 minutes per day) to help burn off any likely deposits before they become problematic.

A good flue temperature thermostat will indicate the flue gas temperature which promotes the conditions to create creosote deposits (around less than 120C°) and therefore the operating temperature to be avoided and is another good reason why we strongly recommend the small investment in this simple to use device.

• **Causes: Poor fuel choice** As previously mentioned unseasoned or damp wood or fuel should always be avoided as these produce excessive soot and creosote. See page 14

STOVE, FLUE OR OTHER COMPONENTS GLOWING RED

• **Prevention**

The Primary and Secondary air controls should be immediately closed to let the fire die down to an acceptable level and to reduce the heat output which will in turn eliminate the glow from the over-heated components. Over-firing is dangerous and could permanently damage or warp your stove and its components. The effects of over-firing are fairly obvious to anyone in the stove industry and will invalidate your Hi-Flame Warranty. Check the stove and the flue system for signs of damage before you re-use the stove.

• **Causes: Over-Firing** This is caused by using the stove at a higher output than recommended for prolonged periods of time and / or over-filling the firebox with fuel. The excessive heat in the flue system produced by over-firing could potentially also lead to a chimney fire (See 'Chimney Fire' above).

SMOKE AND FUMES ESCAPING INTO THE ROOM

When properly installed and operated your stove should not normally emit fumes or smoke into the room. When first using the stove it is normal to experience paint fumes or see light smoke rising from some of the stove's painted surfaces, but these should eventually pass as the paint cures. Occasional minor smoke escape may also occur during refuelling process. However, persistent smoke or fumes could be dangerous and in this

situation you should take immediate avoiding action.

• **Prevention**

Open doors and windows to ventilate the room and let the fire go out to allow the stove to cool. Never pour water onto the fire as this could cause cast iron components to break

Most importantly, never re-light the stove until the problem has been identified and solved. If in doubt, in the first instance always seek the expert advice of your approved installer, or authorised Hi-Flame dealer.

There are a number of factors, either alone or combined, which could cause such problems:

• **Causes: A blockage** When safe to do so, examine the flue-way above the baffle plate as well as the flue pipe and chimney system via the appropriate inspection hatches and clear any soot blockages. Excessive deposits could also indicate that the chimney or flue itself also needs cleaning (see page 34).

• **Causes: Inadequate supply of combustion air** Check that any permanent air vent fitted to supply the extra combustion air required for the stove has not been accidentally blocked. Remember there should never be an extractor fan in the same room as a stove, even in a large open plan area. A simple way of checking whether or not the stove is receiving enough combustion air is to open a window in the same room as the stove whilst the stove is operating. If this improves the problem then this would certainly indicate that the stove is being starved of

combustion air and the advice of the original installer should be sought.

• **Causes: Extreme weather conditions** High winds or freezing temperatures can also temporarily effect the performance of the chimney draught and consequently its effectiveness in removing smoke and fumes from the stove's firechamber. In the case of freezing temperatures it is important to build a larger pre-fire than normal to quickly provide the additional heat needed to warm the flue system and to counteract the much lower temperatures at the exit point of the chimney. Please see the section on lighting your stove on page 17.

• **Causes: High winds** If the problem is associated with high winds and it becomes a regular occurrence, then you will need to fit a specialist chimney cowl. These are designed to provide a stable draught and prevent specific types of problems. Specifying the right cowl should always be left to an approved installer.

• **Causes: Flue Exit** Check, especially at the beginning of the heating season, that summer tree growth has not interfered with the free passage of smoke and flue gases from the chimney top.

OVERHEATING OR EXCESSIVE FUEL CONSUMPTION

This can be caused by a number of factors.

• **Causes: Excessive Chimney Draught** This limits the effectiveness

of the air controls so that the fire burns with very strong bright yellow flames and with very little difference when the air controls are operated. In such circumstances an adjustable draught stabiliser in the flue pipe may need to be fitted to ensure that the stove will always operate under a stable draught to allow the stove's controls to function correctly. In the interests of safety, because draught stabilisers limit the exit of flue gases from the stove, they should only ever be specified, fitted and subsequently tested by an approved installer.

• **Causes: Fuel** The fuel itself may be of poor quality. For example pine and other softwoods will burn much quicker than a good hard wood log, such as Oak. Please read the section on hard and soft woods on page 14.

• **Causes: Faulty Door Seals** The rope seals around the firechamber door could have become worn and may not create the air-tight seal needed for the Primary and Secondary air controls to function correctly. When the stove is cold, you can easily check this seal by placing strips of paper at various points between the door and chamber and checking that when the door is closed it grips this paper. Any paper which can be removed easily would indicate a weakness of the door seal in that particular spot, in which case a complete new rope seal should be fitted. See the section on fitting a rope seal, page 37.

STOVE NOT PROVIDING ENOUGH HEAT

This problem is also usually indicated by dull orange lifeless flames and wood that remains black when burning instead of light grey. A flue temperature gauge will provide you with the best indication of whether or not your stove is operating effectively.

- **Causes: Poor fuel** Poor heat output is more than likely caused by poor fuel, such as 'green' or unseasoned wood. We cannot over-estimate how critical it is to use fully seasoned dry wood. The easiest way to check whether your wood is fully seasoned is to invest in a moisture meter specifically designed for testing wood fuel. These are relatively inexpensive and can be purchased from your stove dealer. When you bear in mind that seasoned wood with a moisture content of less than 20% will give you approximately 50% more heat than unseasoned wood, a moisture meter is modest investment which will more than pay for itself. See page 14

Unseasoned wood introduces unwanted moisture into the fire-chamber, reducing the stove's operating temperature and thus the effectiveness of the air wash system. In addition it will cause problems of increased soot and harmful creosote deposits within the flue system.

Softwoods such as Pine produce significantly less heat output than hardwoods.

- **Causes: Air controls** Ensure that you fully understand the difference that using the Primary and Secondary air

controls make to the performance of the stove and the best way to burn your wood fuel. See pages 16 – 21

- **Causes: Inadequate Combustion Air** A stove starved of combustion air, even when the Primary and Secondary air controls are in the fully open position, will provide limited heat output. Check that any permanent air vent fitted to supply the extra combustion air required for the stove has not been accidentally blocked. Remember there should never be an extractor fan in the same room as a stove, even in a large open plan area.

A simple way of confirming whether or not the stove is receiving enough combustion air is to open a window in the same room as the stove. If this improves the problem then this would certainly indicate that the stove is being starved of combustion air and the advice of the original installer should be sought.

- **Causes: Blockages** When safe to do so, examine the flue-way above the baffle plate as well as the flue pipe and chimney system via the appropriate inspection hatches and clear any soot blockages. Excessive deposits could also indicate that the chimney or flue itself also needs cleaning. See page 34

GLASS STAINING OR BLACKENING

Glass can be cleaned easily if it is undertaken regularly and the deposits are not allowed to build up. A proprietary stove glass spray or gel is strongly recommended – see page 36.

- **Causes: Air Controls** Ensure that you fully understand how the Airwash system works and that you have determined, through some trial and air, the correct balance between Primary and Secondary air that your stove needs. Generally, try to use more Secondary air as this air flows down and over the glass to help burn and wash away any particulates that have accumulated there. See pages 16 – 21

- **Causes: Poor fuel** Burning damp or unseasoned wood will cause the glass to stain as the moisture from the fuel considerably reduces the firechamber temperature reducing the effectiveness of the Airwash system. ‘Green’ wood will also encourage sticky deposits on the glass which will prove difficult for the impaired Airwash system to remove.

- **Causes: Continuous low burning** Continuously burning your stove with a very low flame, such as slow overnight burning will also cause this problem because the Airwash does not get hot enough and some blackening of the glass should be considered a ‘trade-off’. In this instance, if you’re sure that the fuel is seasoned and dry, then burning the stove at very high temperature for a short period after a long slow burn will usually burn off any sooty deposits. Glass can be cleaned easily if it is undertaken regularly and the deposits are not allowed to build up. A proprietary stove glass spray or gel is strongly recommended – see page 36.

ROUTINE CHECKS

During routine checks if you notice anything wrong with your stove then it should be rectified immediately. Never use a stove that you know is not fully functioning – this includes flue components.

- Check your flue system at least once a month using one of the recommended inspection hatches in the flue pipe. After a few checks you will notice a pattern of soot build-up to enable you to determine the inspection and cleaning period best suited to your stove’s operation.
- Check and clear the stove’s baffle plate and flueway at least once a month – see page 34.
- Regularly visually inspect any flue pipe joints where fire cement has been used and replace any missing or damaged cement seals using the appropriate heat-resistant fire cement.
- Make sure the door maintains a good tight fit and visually inspect the door rope seals for fraying or other signs of wear. Test the seal if you suspect that it is no longer air-tight – see page 37.
- Check that the glass is not chipped or cracked and that the glass sealing tape is still in good condition. Replace if necessary – see page 36.

STANDING DOWN

There will be some point in the year when you will not need to use your stove for a considerable time and taking care to clean it thoroughly then will save you much time later. This is also a good time to get your chimney swept too as this will prevent any soot build up from falling inside the stove 'caking' and blocking the flueway.

- Remove and clean any deposits from the top of the baffle plate and check for wear.
- Remove any debris and deposits from the inside of the stove particularly at the entrance to the flueway.
- Empty the ash pan and thoroughly clean out the ash pan chamber.
- Check the rope seal and replace damaged ropes that do not provide a good seal – see page 37.
- Check any fire cement bonds around the flue joints, particularly where they connect to the stove. Remove any loose cement and re-seal.
- Check the vermiculite firebricks and replace any that are becoming very thin or have crumbled to reveal the cast iron sides of the stove.
- Check the grate for signs of wear. Excessive wear, such as grate bars or log retaining bars which are bent or warped, could be an indication of over-firing or using inappropriate fuels such as petroleum coke. Order genuine replacement components from your authorised Hi-Flame dealer (or in case of difficulty your National Distributor) – see page back cover.

ROUTINE MAINTENANCE

Please note: In line with other stove manufacturers, Hi-Flame baffle plates, fire grates and firebricks are regarded as 'consumable' items and are therefore not covered under your warranty – for full warranty details please refer to page 38. Only use genuine Hi-Flame replacement parts which you can buy from your approved Hi-Flame stockist.

• **Cleaning the Baffle Plate and Flueway**

During the heating season check the flueway and baffle plate at least once a month to start with and remove any soot deposits. Should these be excessive then have your chimney and flue cleaned. At the same time review your choice of fuel and the way that you operate the stove.

Regular long periods of slow or overnight burning can create excessive soot because the stove is not operating at the temperature required to burn off most of the sooty. Damp or unseasoned wood will also have similar effect.

To find a local registered sweep visit the National Association of Chimney Sweeps (NACS) www.nacs.org.uk or a similar professional body.

• **Removing or replacing the baffle plate**

In order to remove the baffle plate, the firebricks need to be removed to provide space to manoeuvre the baffle plate downwards and outwards. See page 35 opposite on how to remove the firebricks.

- 1** Remove all the firebricks and inspect

for signs of deterioration and replace if necessary.

2 Push the baffle plate upwards as far as it can go on the left or right hand side, whichever is easier. This angle should then provide you with enough space to enable the baffle to clear the retaining ledges on which it was located.

3 Drop the baffle down at an angle to clear the ledges and at the same time swing the lower end towards you, continuing moving it out of the fire chamber. Space will be tight but you should still be able to remove it.

4 Inspect and replace the plate if necessary ensuring that any soot and debris are removed from the flueway.

5 Reverse these instructions to re-fit the baffle. Make sure the baffle is securely located on all retaining ledges and that it makes complete contact with the fire chamber back.

• Firebricks

Regularly inspect the condition of the vermiculite firebricks. Please note that minor cracks are perfectly normal due to the high temperatures created inside the stove. If necessary small cracks can be repaired using a proprietary heat resistant fire cement (your stove dealer should be able to advise you). Bricks only need replacing if they have crumbled or part of the brick has broken away revealing the stove bodywork. Firebricks are deemed as 'consumable' and are therefore not covered under your Warranty.

To replace a firebrick see right.

• Replacing the Firebricks

Firebricks only need replacing when they have become thin or are crumbling and / or the cast iron fire chamber walls have become exposed. Hairline cracks are acceptable and larger cracks can be repaired by using a proprietary fire cement.

1 Make sure the stove is cold and that any ash has been removed from the fire chamber. Protect any decorative floor coverings.

2 Remove all three of the log retaining bars at the front by lifting upwards.

3 There are two right angle retaining clips at the top of the left and right hand side firebrick pairs. These have a slot on the top which 'locks' the clips on to the vertical lid retaining bars. Slide the clips towards you. This should enable you to easily remove the firebrick pairs. Please note, occasionally the side bricks may need to be eased upwards and outwards to lift them clear from the base retaining lip on the fire grate carrier frame.

4 The rear firebrick can then also be easily removed.

5 At this point it is probably worth dropping the baffle plate down to remove any build up of soot or other debris (see page 34 left).

6 Replace the firebricks as necessary, putting the rear firebrick in place first, followed by the side pairs and retaining clips.

• Chimney Cleaning

The Baby Gabriel can be swept through

the stove by simply removing the baffle plate – see above. Sweep your chimney before installation and then at the end of each heating season when you stand down your stove. Burning seasoned dry wood means that you will probably need to sweep every three months. The amount of soot deposits removed each time is a good indication of how often you should sweep and as you begin to understand your stove and the wood you burn you can adjust the cleaning intervals accordingly. If in doubt seek the advice of a registered chimney sweep who has experience of stoves.

• **Cleaning the Glass**

Using damp or ‘green’ unseasoned wood, filling with small fuel loads or operating the stove at low temperatures (slow overnight burning) will reduce the effectiveness of the Airwash system and cause the glass to stain. Do not allow such staining to build up as it will become more difficult to remove after each firing. When used regularly, a proprietary scratch-resistant stove glass cleaning gel or spray, which can be supplied by your stove dealer, removed with a soft cloth, should be sufficient to keep the glass in pristine condition. Make sure the glass is cold before you apply such cleaners, as applying a cold solution to hot glass could create a thermal shock within the glass causing the glass to crack. Also make sure that all traces of the cleaning fluid have been removed and the glass is thoroughly dry as any residue can be ‘baked’ on causing unsightly smearing.

Read the section on wood fuels and burning on pages 14 – 21.

• **Replacing the Glass**

Never use your stove if it has cracked or missing glass. Your Hi-Flame dealer can quickly supply you with a new piece of heat resistant glass should you ever need it – just let them know the stove name and model number. Only use heat-resistant glass as this is made to withstand temperatures of up to 800°C.

Remove the screws and glass clamp washers from each corner and place them in a safe place. Always use the correct sized Phillips crosshead screwdriver and use releasing oil if the screws prove difficult to remove. Be careful not to dislodge the ribbon seal. If this is damaged or worn replace it completely. Loose ribbon can be held in place with rope seal glue available from your dealer. Lubricate the screws and holes and reverse the process, being careful not to over-tighten the screws and clamps in case you break the glass.

• **Maintaining the Paint Finish**

Your stove has been finished with heat-resistant paint (except for enamelled models) and is very easy to maintain. Regularly remove ash and dust from surfaces with a soft cloth or brush. To maintain the original paint finish you can use traditional ‘stove black’ polish which your Hi-Flame dealer can supply. Make sure the stove is cold and use protective gloves as this type of polish can cause deep staining to the skin and fingernails.

Repair worn or scratched surfaces with a proprietary heat-resistant spray paint made specially for stoves, also available from your stove dealer. Never

use an aerosol spray on, or near, the stove when it is burning or it is hot.

• **Models with an Enamel Finish**

In order to keep the stove's enamel surfaces in pristine condition regularly wash them with a soft cloth and mild soap when the stove is cold. Ensure that any excess moisture is removed at the end of the washing process. Do not use any cleaner which has an abrasive content as this will remove the shine from the enamel. Any heavy staining caused by wood fuel residue can be removed by soaking the affected area with stove glass cleaner and, once dissolved, removing and polishing with a soft cloth. Any chips in the enamel should be repaired immediately with an appropriate enamel repair kit to avoid the damaged enamel flaking off and the area becoming bigger.

• **Door Rope Seals**

It is important that you maintain a tight door seal as this prevents unwanted air leaking into the firechamber and helps make the Primary and Secondary air more effective in controlling the fire.

When the stove is cold, to check the door stove seal, place strips of paper between the door and 'door frame' and shut the door. If you have to pull hard to remove these or they tear, then you have an effective door seal. If these can be easily removed or if they slide around you will need to replace the door seal. Your new Hi-Flame stove is supplied with a spare rope seal for the door. To replace, carefully remove the old seal and completely clean the seal channel of debris and old glue. Use

liberal amounts of proprietary heat resistant fire rope glue to hold the rope in position and glue both ends to ensure a well-sealed joint.

Replacement rope should be 12mm dia.

• **Replacing the fire grate**

1 Make sure the stove is cold, the ash pan has been removed and that the fire chamber is also clear of ash.

2 Unscrew the chrome riddling bar knob. Rotate the fire grate manually so that the bar clears the stove wall. NB On some early models there is also an additional connector screw joint half way along the riddling bar which will also need to be disconnected.

3 Push the fire grate upwards from underneath so that both the grate and bar can then be lifted upwards and removed.

4 Reverse these instructions to re-fit the replacement grate. Ensure that the riddling function is still working.

5 If the fire grate carrier frame also needs to be replaced then the firebricks and baffle will also need to be removed to provide space to maneuver the old and new carrier frames inside the fire chamber – see page 34 and 35.

• **Replacement Parts**

In the interests of safety, only ever use genuine Hi-Flame replacement components – see back cover.

HI-FLAME® WARRANTY

VERY IMPORTANT:

Your new Olymberyl Baby Gabriel HF217-SE stove has been CE EN13240 tested in the UK to ensure that it meets strict UK and Irish constructional, performance and safety standards.

It is not the responsibility of Hi-Flame or their distributors to ensure that the appliance is installed and operating correctly at the time of the installation.

This is strictly the responsibility of the stove owner and any complaints regarding the performance of the installation should be addressed to the stove dealer or the stove installer.

Hi-Flame offers the original retail purchaser a 1 Year Warranty with a further limited 4 Year Extended Warranty subject to the following terms and conditions being met. Claims under this Warranty must be reported in the first instance to the dealer you purchased the stove from. In the unlikely event of a Warranty claim being made the claim will only be entertained by Hi-Flame or their distributors if it follows this procedure and complies with the Terms and Conditions set out below.

TERMS AND CONDITIONS

Please note: All claims must follow this procedure.

Your stove is guaranteed against defects subject to the following conditions:

1 The stove must have been installed by a qualified / government recognised stove installer and upon completion

the appropriate Hetas or Building Notice Certificate of Completion, which specifically covers the installation of the stove, must have been issued. A copy of this must be attached to the claim form. *For legal and insurance reasons, without this approved paperwork, the stove installation must be regarded by Hi-Flame as illegal and potentially life-threatening and therefore we cannot entertain the Warranty claim (This does not limit your statutory rights). In such instances you must contact the stove installer.*

2 The sales receipt or invoice for the stove must be kept as proof of purchase and a copy attached to the claim.

3 The serial number of the stove must not be damaged or missing and must be quoted on the claim.

4 You must not have used the stove to burn any of the prohibited fuels listed in this instruction manual.

5 The stove must have been continuously kept in a serviceable condition and you must not have allowed the stove to corrode. *Warranty claims for stoves which are more than 12 months old must include the annual service record and a copy should be attached to the Warranty claim.*

6 You must not have modified the construction of the stove in any way.

7 The stove must not have been used for commercial purposes (eg rented or holiday accommodation, public bar) where the stove's operation could be subject to abuse from people not familiar with its safe operation.

What the Hi-Flame Warranty covers

- Bodywork
- Doors, Door Handles and Door Hinges
- Spigot / Flue collar
- Primary, Secondary and Tertiary Air Controls
- Ash Pan and Multi-Purpose Tool

Hi-Flame guarantee that your product will be free from defective parts, materials and workmanship at the time of purchase by the original consumer for a period of 1 year for components, bodywork casing and door (parts and labour), excluding consumable parts.

The optional further 4 Year Extended Warranty for the bodywork casing, door and boiler (parts only) is only applicable if the Warranty Card has been completed in full (including the Installer / installation requirements) and it has been posted to Hi-Flame for our records.

Hi-Flame will repair or replace at its option any stove or stove part thereof found to be defective under these Warranty Terms and Conditions.

5 year warranty, your reasonable expenses (provided receipts are provided to us) will be reimbursed and an appropriate replacement supplied, subject to model availability.

What it DOES NOT cover

In line with other manufacturers the Warranty does NOT cover the following 'consumable' items:

- Fire Ropes and Gasket Seals
- Heat Resistant Glass
- Baffle / Throat plate
- Fire Grate and Fire Grate Carrier Frame

- Fire Cemented Joints
- Fire Bricks (where applicable)
- Painted surfaces

The Warranty does not cover an illegally installed stove (see *point 1 above*).

The Hi-Flame Warranty does not cover parts deemed to be consumables which include paint, firebricks, fire grates, vermiculite panels, smoke deflection plates (baffle plates), gaskets, rope seals and heat-resistant glass.

Limits of Warranty

The Hi-Flame Warranty is not transferable and applies to the original retail purchaser only. It does not cover the failure of the appliance due to accidental damage, misuse or abuse, modification, illegal installation, repairs (other than those by the authorised dealer) or failure to maintain the stove in a serviceable condition.

Under no circumstances shall Hi-Flame be liable for any incidental or consequential damage claims of any nature whatsoever arising from the non-conformance of the stove under the terms of the manufacturer's Warranty. These include loss of profit, commercial losses, transport costs and damage during transport, costs in connection with any dismantling and reassembling of the stove and its installation components. The maximum value of the Hi-Flame Warranty cover shall not exceed the value of the dealer's original purchase price.

These terms and conditions do not affect, nor or they intended to affect, your statutory rights.

ANNUAL SERVICE

In the interests of safety it is important that your Hi-Flame stove is serviced on an annual basis in accordance with the instructions outlined below. This should be carried out by a suitably qualified person such as your original approved installer, a Hetas or INFO registered installer or your authorised Hi-Flame dealer.

When the stove is cold strip, clean and inspect it.

Internal Components Remove and inspect the following:

- Baffle Plate
- Side Firebricks
- Grate Assembly
- Ash Pan

Use a wire brush to clean the baffle plate and grate assembly. Use a soft brush on the firebricks and handle these with care as they become fragile with continuous use. Wire brush the inside of the stove and remove all ash and debris from inside the stove and the ash pan chamber.

Check all parts for wear or damage and replace as necessary. Some surface wear is normal on firebricks and these only need replacing when they are very thin or have crumbled to reveal the stove bodywork.

Re-fit all the internal parts.

Stove Glass Check the glass for chips or cracks and the glass seal condition and replace if necessary. Thoroughly clean the stove glass on both sides.

Door Seal Check that this continues to make an air-tight seal and replace if necessary. Ensure that the new rope joint is also in the middle at the base of the rope seal channel. Replacement door rope seal should be 12mm dia. See page 37

External Bodywork All external surfaces should be dusted with a soft cloth or light brush.

- Examine all paintwork for signs of wear and re-paint these areas using an appropriate heat-resistant aerosol paint. *Warning: do not use the aerosol if the stove is alight or hot.*

- When the aerosol paint has dried, apply traditional stove black polish to all painted surfaces

- Lightly oil the hinges and locking mechanism

Air Controls When standing down at the end of the heating season these should be left on the open position to allow some movement of air which will help avoid condensation and moisture building up inside the stove and flue system. These can be closed up to 50% if it gets too draughty.

Flue Pipe Connections Check all flue collar and pipe connections, where applicable, for any crumbling or missing fire cement seals. Remove any failed seals and re-seal using the appropriate heat-resistant fire cement.

Important In the interests of safety use only genuine Hi-Flame replacement parts which are readily available from your authorised dealer – see back cover.

FIRST SERVICE

Work carried out:

Date

Next Service Due

Signed

Print

Dealer's Stamp or HETAS Registration Number

SECOND SERVICE

Work carried out:

Date

Next Service Due

Signed

Print

Dealer's Stamp or HETAS Registration Number

THIRD SERVICE

Work carried out:

Date

Next Service Due

Signed

Print

Dealer's Stamp or HETAS Registration Number

FOURTH SERVICE

Work carried out:

Date

Next Service Due

Signed

Print

Dealer's Stamp or HETAS Registration Number

FIFTH SERVICE

Work carried out:

Date

Next Service Due

Signed

Print

Dealer's Stamp or HETAS Registration Number

SIXTH SERVICE

Work carried out:

Date

Next Service Due

Signed

Print

Dealer's Stamp or HETAS Registration Number

SEVENTH SERVICE

Work carried out:

Date

Next Service Due

Signed

Print

Dealer's Stamp or HETAS Registration Number

EIGHTH SERVICE

Work carried out:

Date

Next Service Due

Signed

Print

Dealer's Stamp or HETAS Registration Number

NINTH SERVICE

Work carried out:

Date

Next Service Due

Signed

Print

Dealer's Stamp or HETAS Registration Number

TENTH SERVICE

Work carried out:

Date

Next Service Due

Signed

Print

Dealer's Stamp or HETAS Registration Number

Baby Gabriel®

HI-FLAME OLYMBERYL SPARES SERVICE

In the interests of safety, only ever use genuine Hi-Flame replacement components. Once you have identified the component you need you can order it from your authorised Hi-Flame dealer – they will know your Baby Gabriel stove inside out!

This appliance has **seai**
been SEAI verified

The output and efficiency data for this appliance have been verified by the Irish government Sustainable Energy Authority of Ireland (SEAI) and is listed on their Home-heating Appliance Register of Performance (HARP) database.



Olymperyl Multi Fuel Stoves

Hi-Flame Fireplace UK Limited
Holmes Chapel Business Park
Manor Lane
Holmes Chapel
Cheshire CW4 8AF

www.hi-flame.com

© Hi-Flame 2015. All rights reserved. Booklet contents may not be copied in whole or in part without the prior written permission of the copyright holder. Olymperyl®, Hi-Flame and Baby Gabriel® are the original registered and trading names of Hi-Flame Fireplace (UK) Limited